

Everbright Micro Push-button Series

Everbright 2007 Series of micro push button are designed for use where either vandalism or heavy duty use is an absolute requirement. Designed for high class environment, the bright LED rim and clear floor illumination are easily visible. No studs required for installation of this model.

The Pressel is manufactured from 316 or 304 stainless steel and is available as standard in a hairline finish, with options for mirror or gold. Floor legends are 12 or 15mm high.

Technical Specification:

Weight :	40 grams
Construction:	Bodies moulded in high grade solid alloy with chromium plated and fix to faceplate by plastic holder .
Pressel:	Standard hairline 316 stainless steel.
LED Voltage:	Single illumination 12/24 a.c./d.c.
LED colour:	Standard illumination in red.
LED current:	22mA
Contact arrangement:	1 N/O
Contact rating:	50mA 24V d.c. (resistive load)
Operation cycle:	1,000,000

The models are available in LED illuminated :

EB07-EL - LED illuminated with Hair-line 316 Stainless Steel Plate.

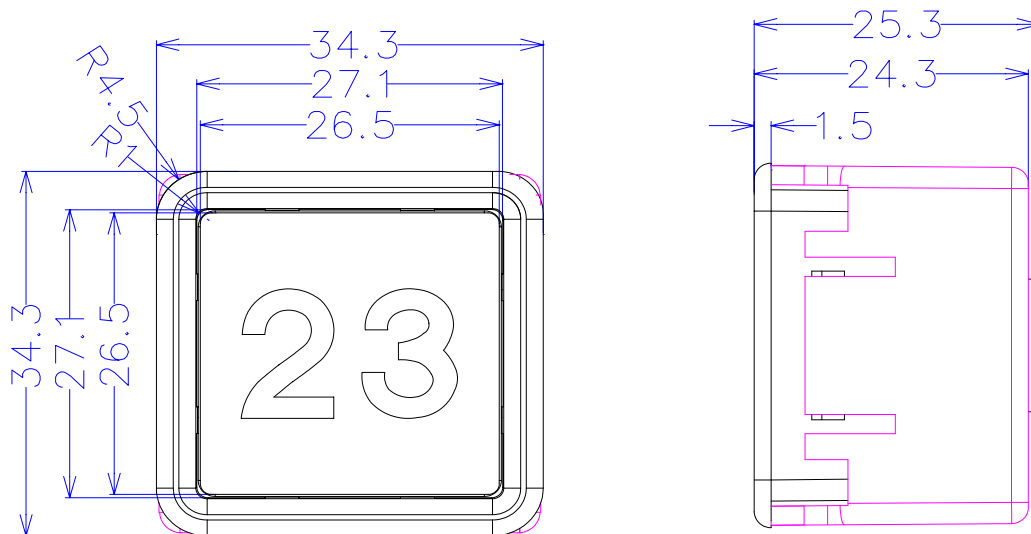

EB-2007EL Vandalism Push-Button